



Whitney Hand Tools

Since 1907

**OFFERING
PUNCHES &
DIES FOR
THESE TOOLS**

**AMERICAN MADE
QUALITY!**



**Punches & Dies and
Die Shoes for**

**#91 & #92 Bench
Mounted Presses**



**#1 and #2 Hand Tool
Punches & Dies**



**ROUND
SQUARE
D-SHAPED
OBLONG**

**For #91 & #92
Bench Mounted
Presses**



Catalog of Hand Operated Tools
& Bench Mounted Presses

815-965-1792

www.AmericanWhitney.com

Table of Contents

Ordering information.....	2
No.1 Hand Operated Punch.....	3
Specifications.....	4
Spare Parts & Tools.....	5
Punch & Die Sizes .006 Clearance.....	6
Punch & Die Sizes .021 Clearance.....	7
Punch & Die Sizes .037 Clearance.....	8
Ordering information.....	9
No.2 Hand Operated Punch.....	10
Specifications.....	11
Spare Parts, Tools & Accessories.....	12
Punch & Die Sizes .006 Clearance.....	13
Punch & Die Sizes .021 Clearance.....	14
Punch & Die Sizes .037 Clearance.....	15
Ordering information.....	16
No.91 Series Bench Press.....	17
No.92 Series Bench Press.....	18
Shapes & Special Punches & Dies.....	19
Tooling Set Ups 0 – 2” dia.....	20
Universal Stripper Set.....	21
Die Shoes & Adapters.....	22
Worktable.....	23
Spare Parts.....	25-26
Standard Punch & Die Sizes .006 Clearance....	27-30
Standard Punch & Die Sizes .021 Clearance ...	31-34

Ordering Information

In order to receive the fastest possible service in processing your order, we request that you include the following information on all of your orders, as indicated below:

- All shaped, special purpose punches and dies should include type and thickness of material to be punched, and type of press that tool will be used on.
- Please specify any deviation from standards, sizes or styles as shown in the catalog.

Shear On Punches

- Round punches – All round punches up thru .5625 diameters are flat faced with center point. All round punches from .5625 diameters thru 2.000 have 1/8 inch twin shear with center point.
- Shaped punches – All shaped punches up thru .5625 equivalent diameters, are flat faced with center pint. All shaped punches from .5625 diameters up thru 2.000 diameters, have 1/8 inch house-top shear and center point.

Orientation

- Shaped punches and dies – All shaped punches and dies are notched for left to right and front to back punching.

Punch and Die Options

- Punches – Special purpose punches, in sizes from 1/16 thru 2” are also available at an additional charge. These options include:
 1. No Shear with Center Point
 2. No shear and No Center Point
 3. High Wear Steel in Round Shapes
 4. High Wear Steel in Shaped Styles

Special Purpose Punches & Dies

- For any special purpose punch and die not listed in the catalog, please contact the American Whitney for a proposal to include price and delivery.

Determining Die Clearance

In order to receive optimum performance from a punch and die, it is necessary that the proper die clearance be provided in the material being pierced. As a general rule, proper die clearance should run 10% to 20% of the thickness of the material being pierced.

	<u>Clearance</u>		
Gage	.006	.021*	.037*
22 Gage thru 14 Gage	Yes		
12 Gage thru 5/32”		Yes	
3/16” thru 1/4”			Yes
*	Use next 1/64 th larger die with .006 clearance		
**	Use next 1/32 nd larger die with .006 clearance		

No.1 Hand Operated Punch



Standard Stock
Round Punch & Die Sizes



- | | |
|-------|--------|
| 1/16" | 11/32" |
| 3/32" | 3/8" |
| 1/8" | 13/32" |
| 5/32" | 7/16" |
| 3/16" | 15/32" |
| 7/32" | 1/2" |
| 1/4" | 17/32" |
| 9/32" | 9/16" |
| 5/16" | |

7.5 Tons

Punching Capacity

Punch Style #1

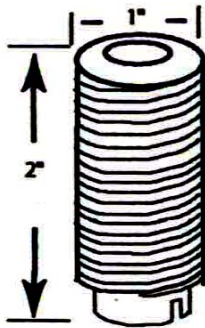
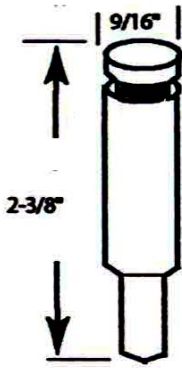

Die Style #1

Punches 1/2" Dia. Hole thru 3/16" mild steel

A heavy duty punch with:

- 7.5 tons punching capacity
- Special gear and cam action for easy operation
- Nickel Plated

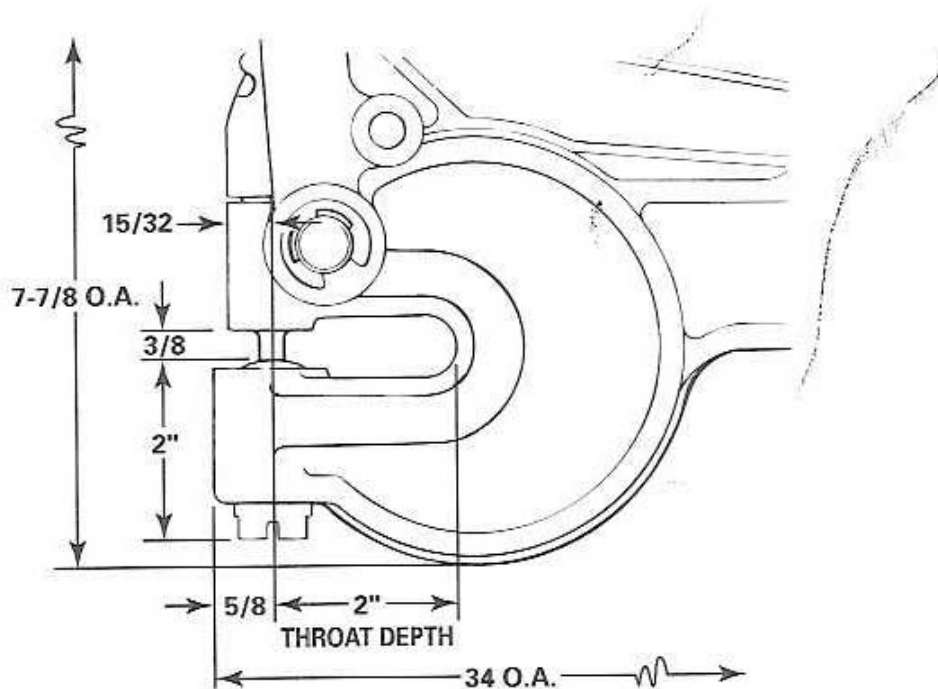

Capacity.....	7.5 Ton
Maximum Diameter (thru 10 ga. Mild steel	9/16"
Maximum Thickness (mild steel, 3/8" dia. Hole....	1/4"
Throat Depth.....	2"
Space between Punch and Die.....	3/8"
Overall Length (includes 24" removable pipe handles).....	34"
Weight (including handles).....	23lbs

Parts for #1 Hand Operated Punch



Part #	Part Name	No. Required
2035	Jaw	1
2037	Lever	1
2039	Intermediate	1
2041	Side Link	2
2043	Roller	1
2057	Lever Pin, 5/8"	2
91338	Retaining Ring	4
2059	Lever Pin, 5/16"	1
4507	Retaining Ring	1
2048	Pipe Handle	2
2052	Die Key	1

#1 Hand Operated Punch

Punches and Dies for material thickness 22ga. - 14ga.

Diameter	Set Of Punch & Die Part No.	Individual Part Number	Punch Or Die	Round Decimal Eq.	Your can order Online or order on the phone!
1/16	101+102M1/16	10100625	Punch	0.0625	Buy Online at: Americanwhitney.com
		10200685	Die	0.0685	
3/32	101+102M3/32	10100937	Punch	0.0937	
		10200997	Die	0.0997	
1/8	101+102M1/8	10101250	Punch	0.1250	Buy Online at: Americanwhitney.com
		10201310	Die	0.1310	
5/32	101+102M5/32	10101562	Punch	0.1562	
		10201622	Die	0.1622	
3/16	101+102M3/16	10101875	Punch	0.1875	Buy Online at: Americanwhitney.com
		10201935	Die	0.1935	
7/32	101+102M7/32	10102187	Punch	0.2187	
		10202247	Die	0.2247	
1/4	101+102M1/4	10102500	Punch	0.2500	Buy Online at: Americanwhitney.com
		10202560	Die	0.2560	
9/32	101+102M9/32	10102812	Punch	0.2812	
		10202872	Die	0.2872	
5/16	101+102M5/16	10103125	Punch	0.3125	Buy Online at: Americanwhitney.com
		10203185	Die	0.3185	
11/32	101+102M11/32	10103437	Punch	0.3437	
		10203497	Die	0.3497	
3/8	101+102M3/8	10103750	Punch	0.3750	Buy Online at: Americanwhitney.com
		10203810	Die	0.3810	
13/32	101+102M13/32	10104062	Punch	0.4062	
		10204122	Die	0.4122	
7/16	101+102M7/16	10104375	Punch	0.4375	Buy Online at: Americanwhitney.com
		10204435	Die	0.4435	
15/32	101+102M15/32	10104687	Punch	0.4687	
		10204747	Die	0.4747	
1/2	101+102M1/2	10105000	Punch	0.5000	Buy Online at: Americanwhitney.com
		10205060	Die	0.5060	
17/32	101+102M17/32	10105312	Punch	0.5312	
		10205372	Die	0.5372	
9/16	101+102M9/16	10105625	Punch	0.5625	Buy Online at: Americanwhitney.com
		10205685	Die	0.5685	

We also make Punches & Dies in Non-Standard forms such as:

- Metric

Call with specifics for a Quote!

#1 Hand Operated Punch

Punches and Dies for material thickness 12ga. - 5/32"

Diameter	Set Of Punch & Die Part No.	Individual Part Number	Punch Or Die	Round Decimal Eq.	Your can order Online or order on the phone!
1/16	101+102S1/16	10100625	Punch	0.0625	Buy Online at: Americanwhitney.com
		10200841	Die	0.0841	
3/32	101+102S3/32	10100937	Punch	0.0937	
		10201153	Die	0.1153	
1/8	101+102S1/8	10101250	Punch	0.1250	Buy Online at: Americanwhitney.com
		10201466	Die	0.1466	
5/32	101+102S5/32	10101562	Punch	0.1562	
		10201778	Die	0.1778	
3/16	101+102S3/16	10101875	Punch	0.1875	Buy Online at: Americanwhitney.com
		10202091	Die	0.2091	
7/32	101+102S7/32	10102187	Punch	0.2187	
		10202403	Die	0.2403	
1/4	101+102S1/4	10102500	Punch	0.2500	Buy Online at: Americanwhitney.com
		10202716	Die	0.2716	
9/32	101+102S9/32	10102812	Punch	0.2812	
		10203028	Die	0.3028	
5/16	101+102S5/16	10103125	Punch	0.3125	Buy Online at: Americanwhitney.com
		10203341	Die	0.3341	
11/32	101+102S11/32	10103437	Punch	0.3437	
		10203653	Die	0.3653	
3/8	101+102S3/8	10103750	Punch	0.3750	Buy Online at: Americanwhitney.com
		10203966	Die	0.3966	
13/32	101+102S13/32	10104062	Punch	0.4062	
		10204278	Die	0.4278	
7/16	101+102S7/16	10104375	Punch	0.4375	Buy Online at: Americanwhitney.com
		10204591	Die	0.4591	
15/32	101+102S15/32	10104687	Punch	0.4687	
		10204903	Die	0.4903	
1/2	101+102S1/2	10105000	Punch	0.5000	Buy Online at: Americanwhitney.com
		10205216	Die	0.5216	
17/32	101+102S17/32	10105312	Punch	0.5312	
		10205528	Die	0.5528	
9/16	101+102S9/16	10105625	Punch	0.5625	Buy Online at: Americanwhitney.com
		10205840	Die	0.5840	

We also make Punches & Dies in Non-Standard sizes such as:

- Metric

Call with specifics for a Quote!

#1 Hand Operated Punch

Punches and Dies for material thickness 3/16" - 1/4"

Diameter	Set Of Punch & Die Part No.	Individual Part Number	Punch Or Die	Round Decimal Eq.	Your can order Online or order on the phone!
1/16	101+102X1/16	10100625	Punch	0.0625	Buy Online at: Americanwhitney.com
		10200997	Die	0.0997	
3/32	101+102X3/32	10100937	Punch	0.0937	
		10201310	Die	0.1310	
1/8	101+102X1/8	10101250	Punch	0.1250	Buy Online at: Americanwhitney.com
		10201622	Die	0.1622	
5/32	101+102X5/32	10101562	Punch	0.1562	
		10201935	Die	0.1935	
3/16	101+102X3/16	10101875	Punch	0.1875	Buy Online at: Americanwhitney.com
		10202247	Die	0.2247	
7/32	101+102X7/32	10102187	Punch	0.2187	
		10202560	Die	0.2560	
1/4	101+102X1/4	10102500	Punch	0.2500	Buy Online at: Americanwhitney.com
		10202872	Die	0.2872	
9/32	101+102X9/32	10102812	Punch	0.2812	
		10203185	Die	0.3185	
5/16	101+102X5/16	10103125	Punch	0.3125	Buy Online at: Americanwhitney.com
		10203497	Die	0.3497	
11/32	101+102X11/32	10103437	Punch	0.3437	
		10203810	Die	0.3810	
3/8	101+102X3/8	10103750	Punch	0.3750	Buy Online at: Americanwhitney.com
		10204122	Die	0.4122	
13/32	101+102X13/32	10104062	Punch	0.4062	
		10204435	Die	0.4435	
7/16	101+102X7/16	10104375	Punch	0.4375	Buy Online at: Americanwhitney.com
		10204747	Die	0.4747	
15/32	101+102X15/32	10104687	Punch	0.4687	
		10205060	Die	0.5060	
1/2	101+102X1/2	10105000	Punch	0.5000	Buy Online at: Americanwhitney.com
		10205372	Die	0.5372	
17/32	101+102X17/32	10105312	Punch	0.5312	
		10205685	Die	0.5685	
9/16	101+102X9/16	10105625	Punch	0.5625	Buy Online at: Americanwhitney.com
		10205938	Die	0.5938	

We also make Punches & Dies in Non-Standard sizes such as:

- Metric

Call with specifics for a Quote!

Ordering Information

In order to receive the fastest possible service in processing your order, we request that you include the following information on all of your orders, as indicated below:

- All shaped, special purpose punches and dies should include type and thickness of material to be punched, and type of press that tool will be used on.
- Please specify any deviation from standards, sizes or styles as shown in the catalog.

Shear On Punches

- Round punches – All round punches up thru .5625 diameters are flat faced with center point. All round punches from .5625 diameters thru 2.000 have 1/8 inch twin shear with center point.
- Shaped punches – All shaped punches up thru .5625 equivalent diameters, are flat faced with center pint. All shaped punches from .5625 diameters up thru 2.000 diameters, have 1/8 inch house-top shear and center point.

Orientation

- Shaped punches and dies – All shaped punches and dies are notched for left to right and front to back punching.

Punch and Die Options

- Punches – Special purpose punches, in sizes from 1/16 thru 2” are also available at an additional charge. These options include:
 5. No Shear with Center Point
 6. No shear and No Center Point
 7. High Wear Steel in Round Shapes
 8. High Wear Steel in Shaped Styles

Special Purpose Punches & Dies

- For any special purpose punch and die not listed in the catalog, please contact the American Whitney for a proposal to include price and delivery.

Determining Die Clearance

In order to receive optimum performance from a punch and die, it is necessary that the proper die clearance be provided in the material being pierced. As a general rule, proper die clearance should run 10% to 20% of the thickness of the material being pierced.

	<u>Clearance</u>		
Gage	.006	.021*	.037*
22 Gage thru 14 Gage	Yes		
12 Gage thru 5/32”		Yes	
3/16” thru 1/4”			Yes
	* Use next 1/64 th larger die with .006 clearance		
	** Use next 1/32 nd larger die with .006 clearance		

No.2 Hand Operated Punch



Standard Stock
Round Punch & Die Sizes

1/16"	9/32"
3/32"	5/16"
1/8"	11/32"
5/32"	3/8"
3/16"	13/32"
7/32"	7/16"
1/4"	1/2"

5 Ton

Punching Capacity

Punch Style #2

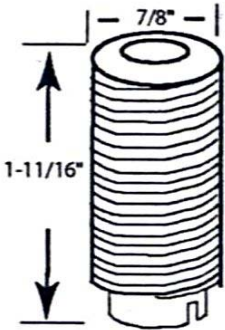
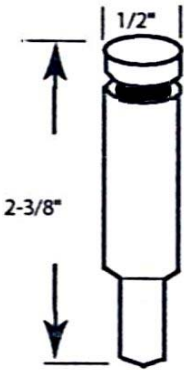

Die Style #2

Punches 1/4" Dia. Hole thru 1/4" mild steel

This durable, lightweight, powerhouse of a punch will provide years of trouble-free service. Unique cam action eliminates undue operator strain. Amenities include:

- 5 ton punching capacity
- Special gear and cam action for easy operation
- Nickel Plated

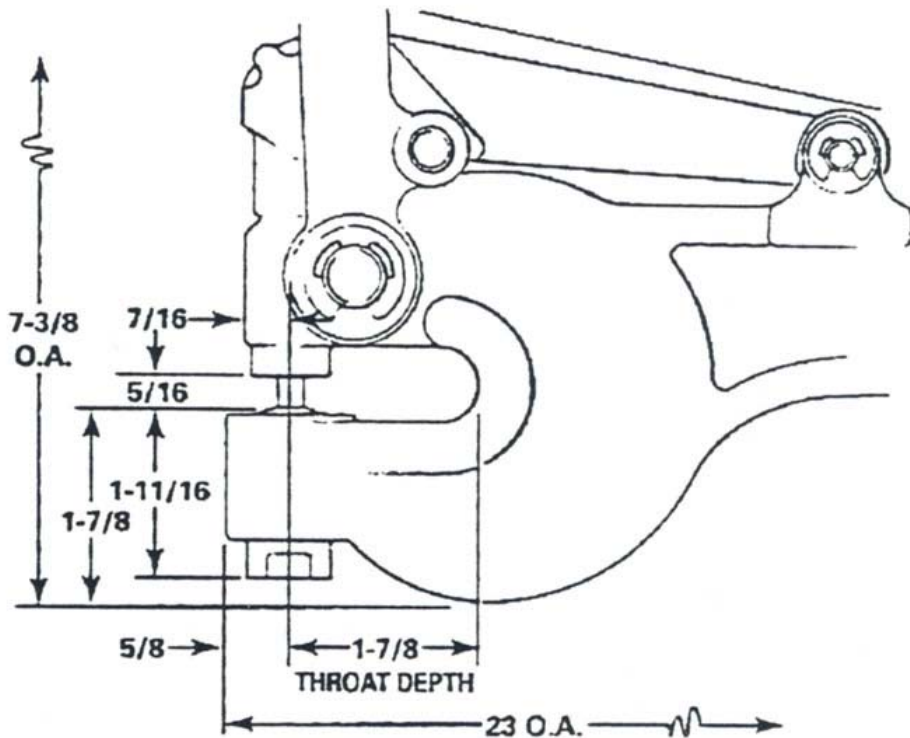

Capacity.....	5 Ton
Maximum Diameter (thru 10 ga. Mild steel	1/2"
Maximum Thickness (mild steel, 9/32" dia. Hole...)	1/4"
Throat Depth.....	1-7/8"
Space between Punch and Die.....	5/16"
Overall Length	23"
Weight	14lbs

Parts for #2 Hand Operated Punch

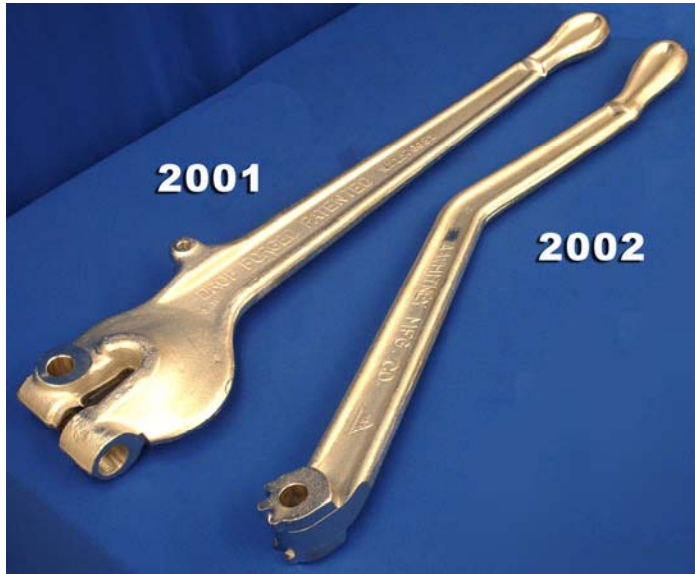

Part #	Part Name	No. Required
2001	Jaw	1
2002	Lever	1
2003	Intermediate	1
2004	Side Link	2
2005	Roller	1
2056	Lever Pin, 5/8"	2
91338	Retaining Ring	4
2058	Lever Pin, 5/16"	1
4507	Retaining Ring	1
2052	Die Key	1

#2 Hand Operated Punch

Punches and Dies for material thickness 22ga. - 14ga.

Diameter	Set Of Punch & Die Part No.	Individual Part Number	Punch Or Die	Round Decimal Eq.	Your can order Online or order on the phone!
1/16	201+202M1/16	20100625	Punch	0.0625	Buy Online at: Americanwhitney.com
		20200685	Die	0.0685	
3/32	201+202M3/32	20100937	Punch	0.0937	
		20200997	Die	0.0997	
1/8	201+202M1/8	20101250	Punch	0.1250	Buy Online at: Americanwhitney.com
		20201310	Die	0.1310	
5/32	201+202M5/32	20101562	Punch	0.1562	
		20201622	Die	0.1622	
3/16	201+202M3/16	20101875	Punch	0.1875	Buy Online at: Americanwhitney.com
		20201935	Die	0.1935	
7/32	201+202M7/32	20102187	Punch	0.2187	
		20202247	Die	0.2247	
1/4	201+202M1/4	20102500	Punch	0.2500	Buy Online at: Americanwhitney.com
		20202560	Die	0.2560	
9/32	201+202M9/32	20102812	Punch	0.2812	
		20202872	Die	0.2872	
5/16	201+202M5/16	20103125	Punch	0.3125	Buy Online at: Americanwhitney.com
		20203185	Die	0.3185	
11/32	201+202M11/32	20103437	Punch	0.3437	
		20203653	Die	0.3653	
3/8	201+202M3/8	20103750	Punch	0.3750	Buy Online at: Americanwhitney.com
		20203810	Die	0.3810	
13/32	201+202M13/32	20104062	Punch	0.4062	
		20204122	Die	0.4122	
7/16	201+202M7/16	20104375	Punch	0.4375	Buy Online at: Americanwhitney.com
		20204435	Die	0.4435	
15/32	201+202M15/32	20104687	Punch	0.4687	
		20204747	Die	0.4747	
1/2	201+202M1/2	20105000	Punch	0.5000	Buy Online at: Americanwhitney.com
		20205060	Die	0.5060	

We also make Punches & Dies in Non-Standard forms such as:

- Metric

Call today with specifics for a Quote!

#2 Hand Operated Punch

Punches and Dies for material thickness 12ga. - 5/32"

Diameter	Set Of Punch & Die Part No.	Individual Part Number	Punch Or Die	Round Decimal Eq.	Your can order Online or order on the phone!
1/16	201+202S1/16	20100625	Punch	0.0625	Buy Online at: Americanwhitney.com
		20200841	Die	0.0841	
3/32	201+202S3/32	20100937	Punch	0.0937	
		20201153	Die	0.1153	
1/8	201+202S1/8	20101250	Punch	0.1250	Buy Online at: Americanwhitney.com
		20201466	Die	0.1466	
5/32	201+202S5/32	20101562	Punch	0.1562	
		20201778	Die	0.1778	
3/16	201+202S3/16	20101875	Punch	0.1875	Buy Online at: Americanwhitney.com
		20202091	Die	0.2091	
7/32	201+202S7/32	20102187	Punch	0.2187	
		20202403	Die	0.2403	
1/4	201+202S1/4	20102500	Punch	0.2500	Buy Online at: Americanwhitney.com
		20202716	Die	0.2716	
9/32	201+202S9/32	20102812	Punch	0.2812	
		20203028	Die	0.3028	
5/16	201+202S5/16	20103125	Punch	0.3125	Buy Online at: Americanwhitney.com
		20203341	Die	0.3341	
11/32	201+202S11/32	20103437	Punch	0.3437	
		20203653	Die	0.3653	
3/8	201+202S3/8	20103750	Punch	0.3750	Buy Online at: Americanwhitney.com
		20203966	Die	0.3966	
13/32	201+202S13/32	20104062	Punch	0.4062	
		20204278	Die	0.4278	
7/16	201+202S7/16	20104375	Punch	0.4375	Buy Online at: Americanwhitney.com
		20204591	Die	0.4591	
15/32	201+202S15/32	20104687	Punch	0.4687	
		20204903	Die	0.4903	
1/2	201+202S1/2	20105000	Punch	0.5000	Buy Online at: Americanwhitney.com
		20205216	Die	0.5216	

We also make Punches & Dies in Non-Standard forms such as:

- Metric

Call today with specifics for a Quote!

#2 Hand Operated Punch

Punches and Dies for material thickness 3/16" - 1/4"

Diameter	Set Of Punch & Die Part No.	Individual Part Number	Punch Or Die	Round Decimal Eq.	Your can order Online or order on the phone!
1/16	201+202X1/16	20100625	Punch	0.0625	Buy Online at: Americanwhitney.com
		20200997	Die	0.0997	
3/32	201+202X3/32	20100937	Punch	0.0937	
		20201310	Die	0.1310	
1/8	201+202X1/8	20101250	Punch	0.1250	Buy Online at: Americanwhitney.com
		20201622	Die	0.1622	
5/32	201+202X5/32	20101562	Punch	0.1562	
		20201935	Die	0.1935	
3/16	201+202X3/16	20101875	Punch	0.1875	Buy Online at: Americanwhitney.com
		20202247	Die	0.2247	
7/32	201+202X7/32	20102187	Punch	0.2187	
		20202560	Die	0.2560	
1/4	201+202X1/4	20102500	Punch	0.2500	Buy Online at: Americanwhitney.com
		20202872	Die	0.2872	
9/32	201+202X9/32	20102812	Punch	0.2812	
		20203185	Die	0.3185	
5/16	201+202X5/16	20103125	Punch	0.3125	Buy Online at: Americanwhitney.com
		20203497	Die	0.3497	
11/32	201+202X11/32	20103437	Punch	0.3437	
		20203810	Die	0.3810	
3/8	201+202X3/8	20103750	Punch	0.3750	Buy Online at: Americanwhitney.com
		20204122	Die	0.4122	
13/32	201+202X13/32	20104062	Punch	0.4062	
		20204435	Die	0.4435	
7/16	201+202X7/16	20104375	Punch	0.4375	Buy Online at: Americanwhitney.com
		20204747	Die	0.4747	
15/32	201+202X15/32	20104687	Punch	0.4687	
		20205060	Die	0.5060	
1/2	201+202X1/2	20105000	Punch	0.5000	Buy Online at: Americanwhitney.com
		20205372	Die	0.5372	

We also make Punches & Dies in Non-Standard forms such as:

- Metric

Call today with specifics for a Quote!

Ordering Information

In order to receive the fastest possible service in processing your order, we request that you include the following information on all of your orders, as indicated below:

- All shaped, special purpose punches and dies should include type and thickness of material to be punched, and type of press that tool will be used on.
- Please specify any deviation from standards, sizes or styles as shown in the catalog.

Shear On Punches

- Round punches – All round punches up thru .5625 diameters are flat faced with center point. All round punches from .5625 diameters thru 2.000 have 1/8 inch twin shear with center point.
- Shaped punches – All shaped punches up thru .5625 equivalent diameters, are flat faced with center pint. All shaped punches from .5625 diameters up thru 2.000 diameters, have 1/8 inch house-top shear and center point.

Orientation

- Shaped punches and dies – All shaped punches and dies are notched for left to right and front to back punching.

Punch and Die Options

- Punches – Special purpose punches, in sizes from 1/16 thru 2” are also available at an additional charge. These options include:
 9. No Shear with Center Point
 10. No shear and No Center Point
 11. High Wear Steel in Round Shapes
 12. High Wear Steel in Shaped Styles

Special Purpose Punches & Dies

- For any special purpose punch and die not listed in the catalog, please contact the American Whitney for a proposal to include price and delivery.

Determining Die Clearance

In order to receive optimum performance from a punch and die, it is necessary that the proper die clearance be provided in the material being pierced. As a general rule, proper die clearance should run 10% to 20% of the thickness of the material being pierced.

	<u>Clearance</u>		
Gage	.006	.021*	.037*
22 Gage thru 14 Gage	Yes		
12 Gage thru 5/32”		Yes	
3/16” thru 1/4”			Yes
*	Use next 1/64 th larger die with .006 clearance		
**	Use next 1/32 nd larger die with .006 clearance		

No.91 & 92 Series Bench Presses

No.91 Bench Press



- Hefty 10 ton capacity press
- Lever operated
- Rugged construction
- All wearing parts are heat-treated
- Uses standard tooling
- Huge selection of special tooling
- Wide work range applications
- Nickel Plated

This press can be used for punching, slotting and louvering, notching angle iron, corner rounding & notching, combination notching, pipe notching, electrical work, and many other applications.

The biggest bench presses available in their class
ANYWHERE!!!

Capacity.....	10 Ton
Maximum Thickness	1/4"
(mild steel, 1/2" dia. Hole)	
Ram Stroke.....	5/8"
Shut Height.....	3-1/8"
Overall Weight	79 lbs

Maximum Diameters:

- 2" thru 12 ga. mild steel
- 1-3/4" thru 1/8" mild steel
- 3/4" thru 3/16" mild steel
- 1/2" thru 1/4" mild steel
- Channel – 2-1/2" flange x 1/4" web
- Angle Iron – 2-1/2" x 2-1/2" x 1/4"

No.91 & 92 Series Bench Presses

No.92 Bench Press

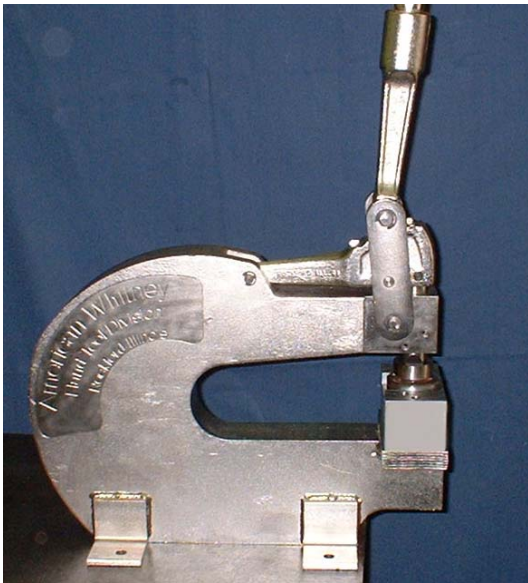

- Hefty 10 ton capacity press
- Lever operated
- Rugged construction
- All wearing parts are heat-treated
- Uses standard tooling
- Huge selection of special tooling
- Wide work range applications
- Nickel Plated
- **10" Throat Depth**

This press can be used for punching, slotting and louvering, notching angle iron, corner rounding & notching, combination notching, pipe notching, electrical work, and many other applications.

The biggest bench presses available in their class
ANYWHERE!!!

Capacity.....	10 Ton
Maximum Thickness	1/4"
(mild steel, 1/2" dia. Hole)	
Ram Stroke.....	5/8"
Shut Height.....	3-1/8"
Overall Weight	155 lbs

Maximum Diameters:

- 2" thru 12 ga. mild steel
- 1-3/4" thru 1/8" mild steel
- 3/4" thru 3/16" mild steel
- 1/2" thru 1/4" mild steel
- Channel – 2-1/2" flange x 1/4" web
- Angle Iron – 2-1/2" x 2-1/2" x 1/4"

No.91 & 92 Series Bench Presses

Punch Unusual Shapes into Metal!
Create Your Cuts!

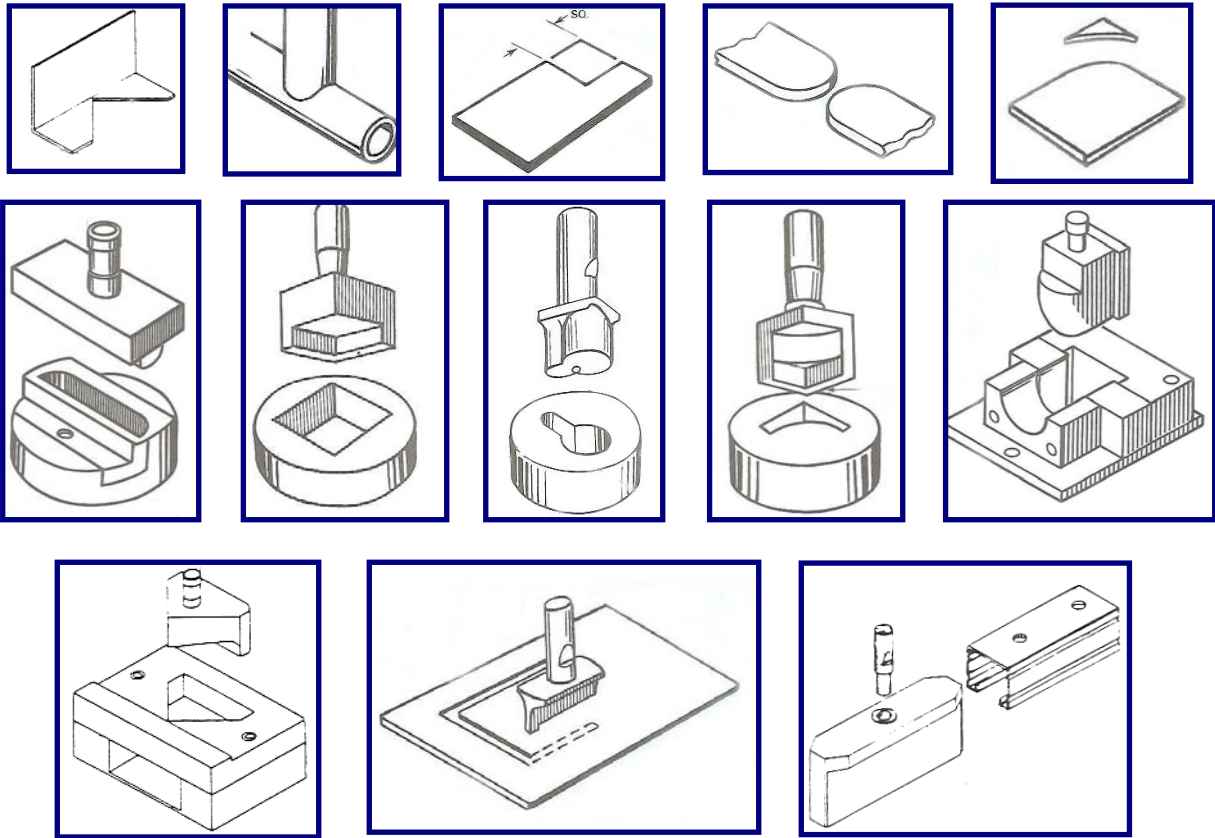

Metal – Vineer – Leather

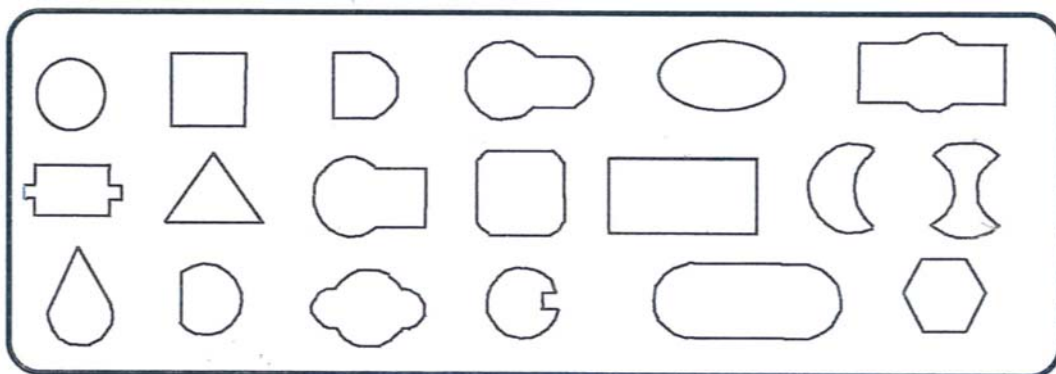

Rounds • Rectangles • “D” Shapes • “DD” Shapes • Hex • Obround

No.91 & 92 Series Bench Presses

TYPICAL TOOLING SET-UP FOR PIERCING HOLES UP THRU 2" DIAMETER

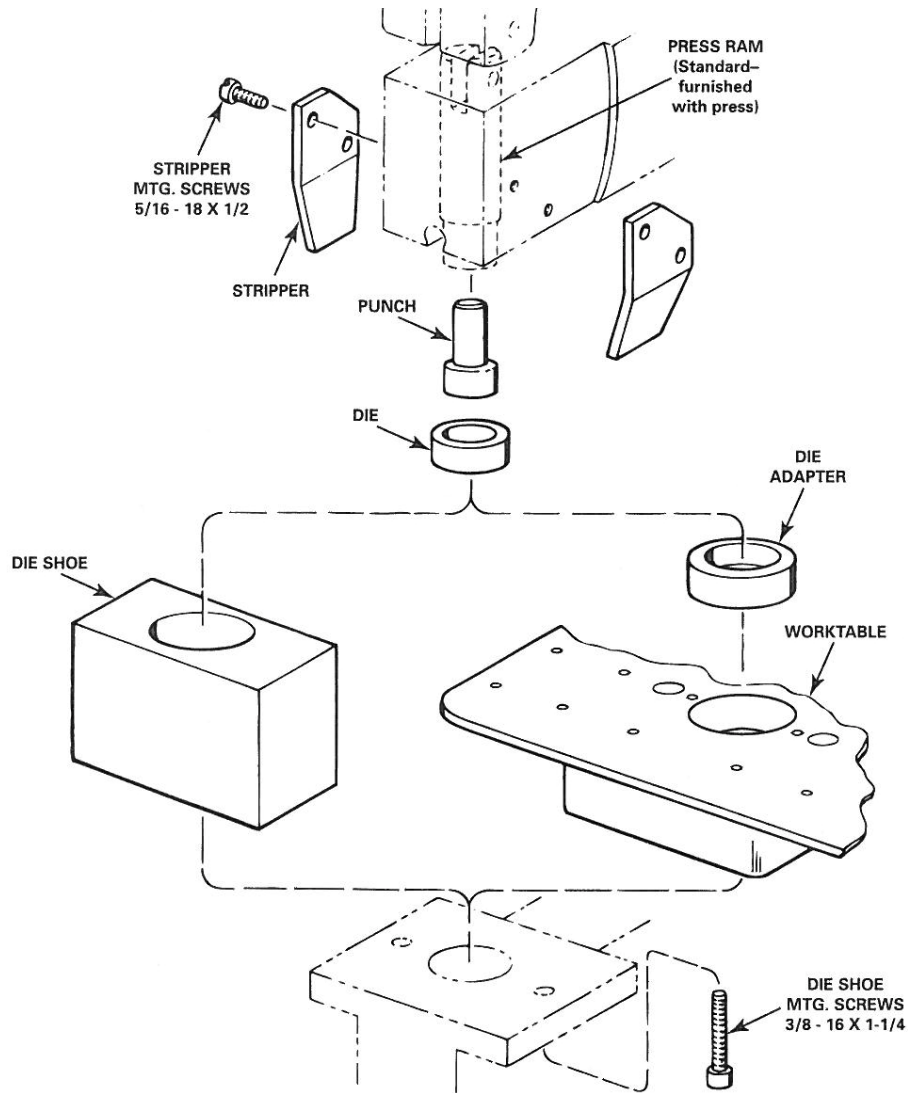

STRIPPERS (one LH and one RH required)

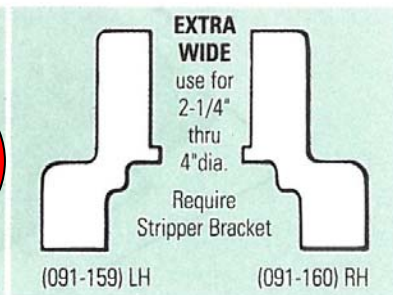
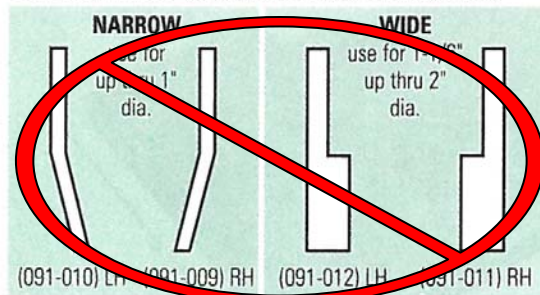

STRIPPER RINGS

for use with extra wide stripper

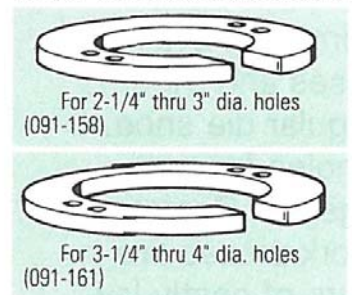

**Replace with Universal Stripper Set
used for both Narrow and Wide
P/N: 91009101112Set See Next Page**

NEW UNIVERSAL STRIPPERS

USE IN PLACE OF 91009 AND 91010

USE IN PLACE OF 91011 AND 91012

Reverse the position to make the narrow strippers into the wide strippers!

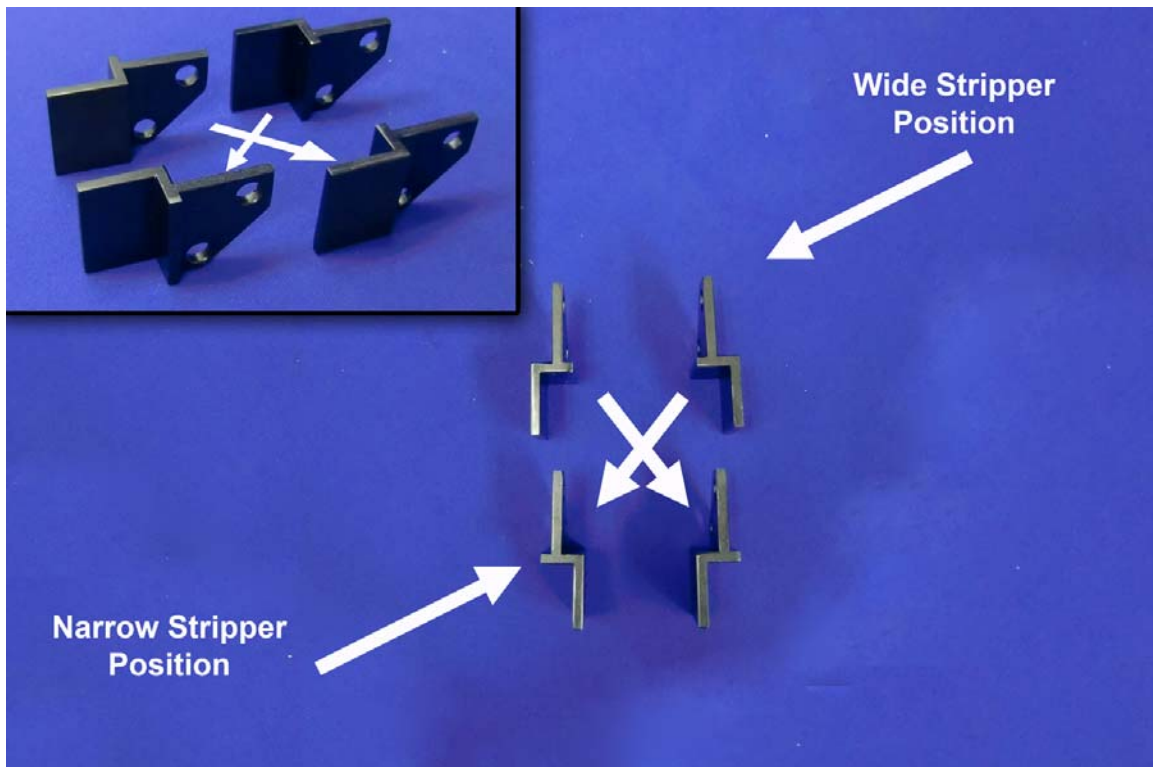

Sold only as a set!

P/N: 91009101112Set

No.91 & 92 Series Bench Presses

DIFFERENT DIE SIZES REQUIRE DIFFERENT
DIE SHOES OR ADAPTERS



**Fits Die Sizes
1/16" thru 5/8"**



**Fits Die Sizes
21/32" thru 7/8"**



**Fits Die Sizes
29/32" thru 1-1/2"**



**Fits Die Sizes
1-17/32" thru 2"**



Universal Die Shoe accepts all die adapters

91028

91306 91307 91308 91309

The image shows a large rectangular die shoe (91028) with a central hole. Below it are four circular adapters of different diameters, labeled 91306, 91307, 91308, and 91309. The text 'Universal Die Shoe accepts all die adapters' is written on the left.

91028-T

The Universal Tooling Package allows you to use all dies up thru 2" without having to purchase multiple die shoes. It comes with all die adapters making for quick change from one die size to the next.

No.91 & 92 Series Bench Presses

WORKTABLE FOR BENCH PRESSES

This popular worktable assembly is available for both the No.91 & No.92 models and mounts in the same manner as a regular die shoe. The worktable has tapped holes for positioning of three adjustable gages. Gaging assures that all duplicate work pieces are accurate and eliminates hours of costly layout time.

91301 – Universal Work Table Assembly

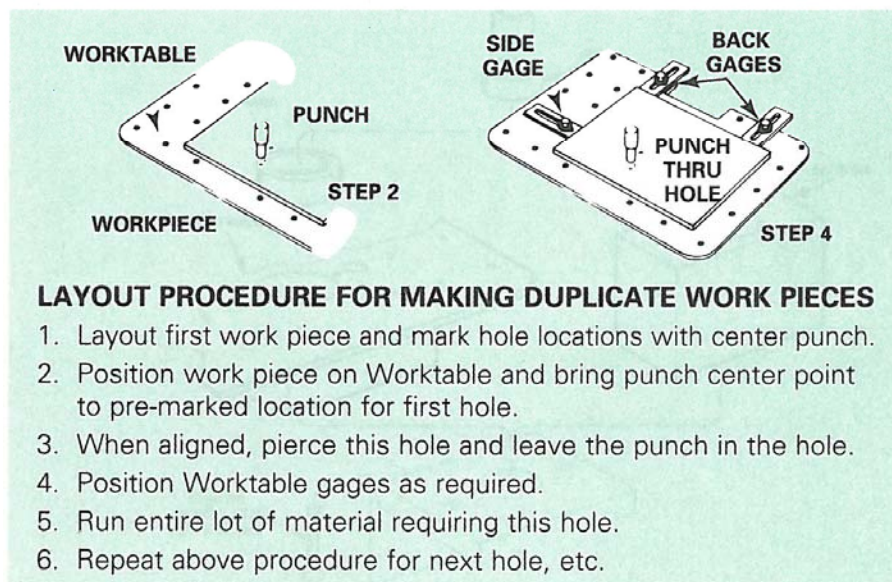

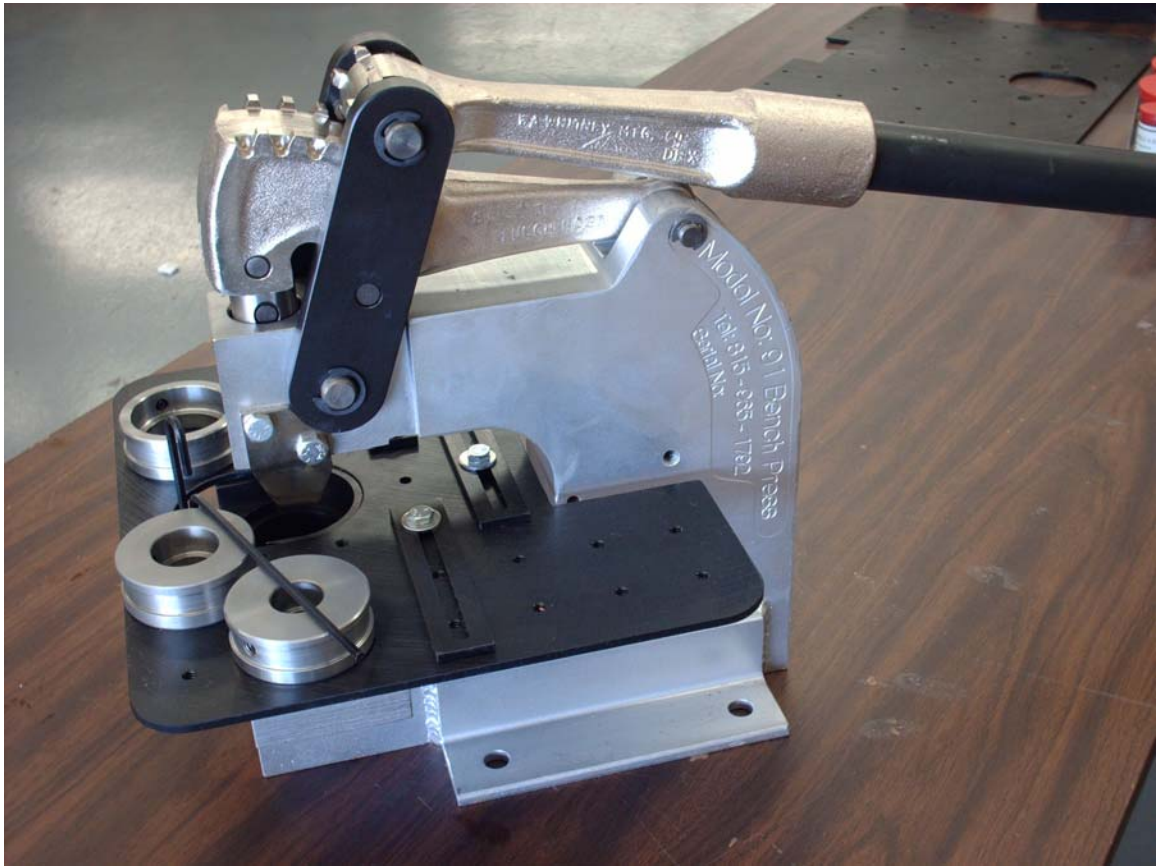

Parts for No.91 & 92 Series Bench Presses

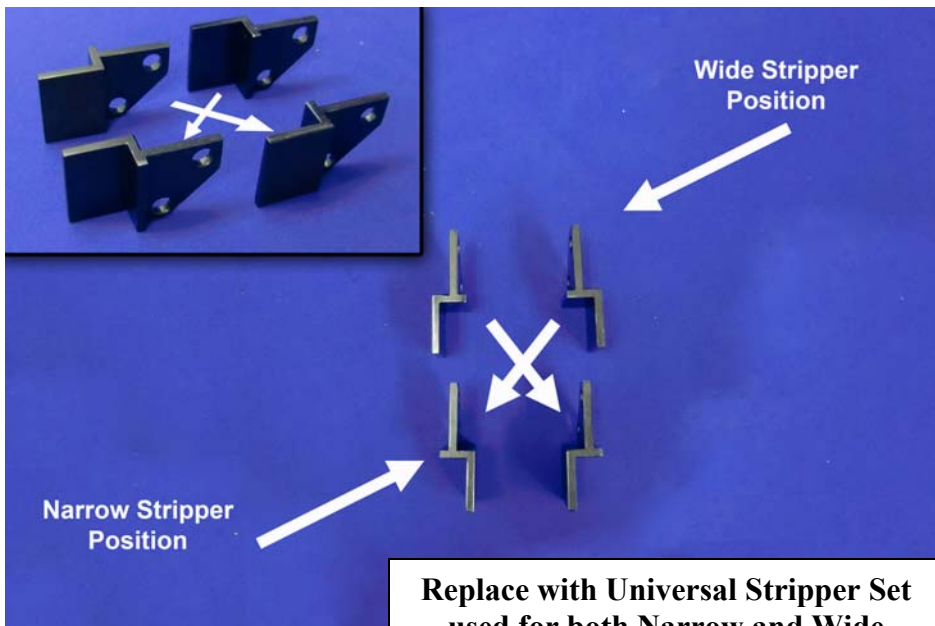

Replace with Universal Stripper Set
used for both Narrow and Wide
P/N: 91009101112Set

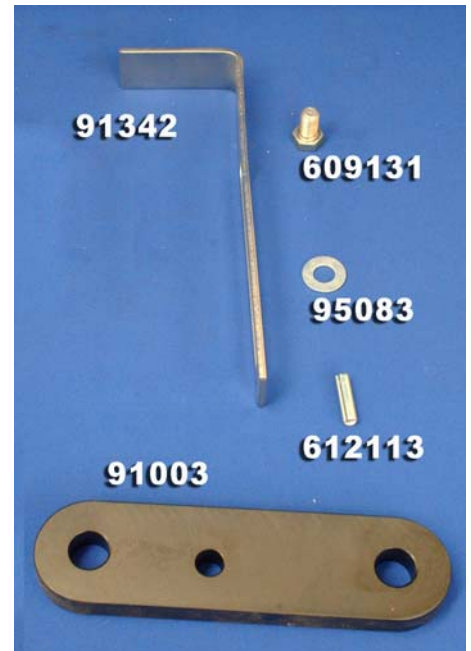

Parts for No.91 & 92 Series Bench Presses

<u>Part #</u>	<u>Part Name</u>	<u>No. Required</u>
2048	Pipe Handle	1
91001	#91 Jaw (not shown)	1
92001	#92 Jaw (not shown)	1
91003	Side Link	2
91004	Intermediate	1
91005	Ram Link	1
91006	Punch Ram	1
91007	Ram Link Pin	1
91008	Intermediate Pin	1
91009	Narrow Stripper (RH)	1
91010	Narrow Stripper (LH)	1
91011	Wide Stripper (RH)	1
91012	Wide Stripper (LH)	1
91013	Roller	1
91337	Lever Pin, 5/8"	2
91338	Retaining Ring	4
91339	Pin	1
91340	Retaining Ring	2
91342	Gage	1
609131	Gage Screw	1
606308	Stripper Screw	4
95083	Gage Screw Washer	1
612113	Roll Pin	1

No.91 & 92 Series Bench Presses

Punches and Dies for material thickness 22ga. - 14ga.

Diameter	Set Of Punch & Die Part No.	Individual Part Number	Punch Or Die	Round Decimal Eq.	Your can order Online or order on the phone!
1/16	9101+9102M1/16	910100625	Punch	0.0625	Buy Online at: Americanwhitney.com
		910200685	Die	0.0685	
3/32	9101+9102M3/32	910100937	Punch	0.0937	
		910200997	Die	0.0997	
1/8	9101+9102M1/8	910101250	Punch	0.1250	Buy Online at: Americanwhitney.com
		910201310	Die	0.1310	
5/32	9101+9102M5/32	910101562	Punch	0.1562	
		910201622	Die	0.1622	
3/16	9101+9102M3/16	910101875	Punch	0.1875	Buy Online at: Americanwhitney.com
		910201935	Die	0.1935	
7/32	9101+9102M7/32	910102187	Punch	0.2187	
		910202247	Die	0.2247	
1/4	9101+9102M1/4	910102500	Punch	0.2500	Buy Online at: Americanwhitney.com
		910202560	Die	0.2560	
9/32	9101+9102M9/32	910102812	Punch	0.2812	
		910202872	Die	0.2872	
5/16	9101+9102M5/16	910103125	Punch	0.3125	Buy Online at: Americanwhitney.com
		910203185	Die	0.3185	
11/32	9101+9102M11/32	910103437	Punch	0.3437	
		910203497	Die	0.3497	
3/8	9101+9102M3/8	910103750	Punch	0.3750	Buy Online at: Americanwhitney.com
		910203810	Die	0.3810	
13/32	9101+9102M13/32	910104062	Punch	0.4062	
		910204122	Die	0.4122	
7/16	9101+9102M7/16	910104375	Punch	0.4375	Buy Online at: Americanwhitney.com
		910204435	Die	0.4435	
15/32	9101+9102M15/32	910104687	Punch	0.4687	
		910204747	Die	0.4747	
1/2	9101+9102M1/2	910105000	Punch	0.5000	Buy Online at: Americanwhitney.com
		910205060	Die	0.5060	
17/32	9101+9102M17/32	910105312	Punch	0.5312	
		910205372	Die	0.5372	

We also make Punches & Dies in Non-Standard forms such as:
Rounds • Rectangles • “D” Shapes • “DD” Shapes • Hex • Obround
 Call today with specifics for a Quote!

No.91 & 92 Series Bench Presses

Punches and Dies for material thickness 22ga. - 14ga. (cont.)

Diameter	Set Of Punch & Die Part No.	Individual Part Number	Punch Or Die	Round Decimal Eq.	Your can order Online or order on the phone!
9/16	9101+9102M9/16	910105625	Punch	0.5625	Buy Online at: Americanwhitney.com
		910205685	Die	0.5685	
19/32	9101+9102M19/32	910105937	Punch	0.5937	
		910205997	Die	0.5997	
5/8	9101+9102M5/8	910106250	Punch	0.6250	Buy Online at: Americanwhitney.com
		910206310	Die	0.6310	
21/32	9101+9102M21/32	910106562	Punch	0.6562	
		910206622	Die	0.6622	
11/16	9101+9102M11/16	910106875	Punch	0.6875	Buy Online at: Americanwhitney.com
		910206935	Die	0.6935	
23/32	9101+9102M23/32	910107187	Punch	0.7187	
		910207247	Die	0.7247	
3/4	9101+9102M3/4	910107500	Punch	0.7500	Buy Online at: Americanwhitney.com
		910207560	Die	0.7560	
25/32	9101+9102M25/32	910107812	Punch	0.7812	
		910207872	Die	0.7872	
13/16	9101+9102M13/16	910108125	Punch	0.8125	Buy Online at: Americanwhitney.com
		910208185	Die	0.8185	
27/32	9101+9102M27/32	910108437	Punch	0.8437	
		910208497	Die	0.8497	
7/8	9101+9102M7/8	910108750	Punch	0.8750	Buy Online at: Americanwhitney.com
		910208810	Die	0.8810	
29/32	9101+9102M29/32	910109062	Punch	0.9062	
		910209122	Die	0.9122	
15/16	9101+9102M15/16	910109375	Punch	0.9375	Buy Online at: Americanwhitney.com
		910209435	Die	0.9435	
31/32	9101+9102M31/32	910109687	Punch	0.9687	
		910209747	Die	0.9747	
1"	9101+9102M1	910110000	Punch	1.0000	Buy Online at: Americanwhitney.com
		910210060	Die	1.0060	
1-1/32	9101+9102M1-1/32	910110312	Punch	1.0312	
		910210372	Die	1.0372	

We also make Punches & Dies in Non-Standard forms such as:
Rounds • Rectangles • “D” Shapes • “DD” Shapes • Hex • Obround
 Call today with specifics for a Quote!

No.91 & 92 Series Bench Presses

Punches and Dies for material thickness 22ga. - 14ga. (cont.)

Diameter	Set Of Punch & Die Part No.	Individual Part Number	Punch Or Die	Round Decimal Eq.	Your can order Online or order on the phone!
1-1/16	9101+9102M1-1/16	910110625	Punch	1.0625	Buy Online at: Americanwhitney.com
		910210685	Die	1.0685	
1-3/32	9101+9102M1-3/32	910110937	Punch	1.0937	
		910210997	Die	1.0997	
1-1/8	9101+9102M1-1/8	910111250	Punch	1.1250	Buy Online at: Americanwhitney.com
		910211310	Die	1.1310	
1-5/32	9101+9102M1-5/32	910111562	Punch	1.1562	
		910211622	Die	1.1622	
1-3/16	9101+9102M1-3/16	910111875	Punch	1.1875	Buy Online at: Americanwhitney.com
		910211935	Die	1.1935	
1-7/32	9101+9102M1-7/32	910112187	Punch	1.2187	
		910212247	Die	1.2247	
1-1/4	9101+9102M1-1/4	910112500	Punch	1.2500	Buy Online at: Americanwhitney.com
		910212560	Die	1.2560	
1-9/32	9101+9102M1-9/32	910112812	Punch	1.2812	
		910212872	Die	1.2872	
1-5/16	9101+9102M1-5/16	910113125	Punch	1.3125	Buy Online at: Americanwhitney.com
		910213185	Die	1.3185	
1-11/32	9101+9102M1-11/32	910113437	Punch	1.3437	
		910213497	Die	1.3497	
1-3/8	9101+9102M1-3/8	910113750	Punch	1.3750	Buy Online at: Americanwhitney.com
		910213810	Die	1.3810	
1-13/32	9101+9102M1-13/32	910114062	Punch	1.4062	
		910214122	Die	1.4122	
1-7/16	9101+9102M1-7/16	910114375	Punch	1.4375	Buy Online at: Americanwhitney.com
		910214435	Die	1.4435	
1-15/32	9101+9102M1-15/32	910114687	Punch	1.4687	
		910214747	Die	1.4747	
1-1/2	9101+9102M1-1/2	910115000	Punch	1.5000	Buy Online at: Americanwhitney.com
		910215060	Die	1.5060	

We also make Punches & Dies in Non-Standard forms such as:
Rounds • Rectangles • “D” Shapes • “DD” Shapes • Hex • Obround
 Call today with specifics for a Quote!

No.91 & 92 Series Bench Presses

Punches and Dies for material thickness 22ga. - 14ga. (cont.)

Diameter	Set Of Punch & Die Part No.	Individual Part Number	Punch Or Die	Round Decimal Eq.	Your can order Online or order on the phone!
1-17/32	9101+9102M1-17/32	910115312	Punch	1.5312	Buy Online at: Americanwhitney.com
		910215372	Die	1.5372	
1-9/16	9101+9102M1-9/16	910115625	Punch	1.5625	
		910215685	Die	1.5685	
1.19/32	9101+9102M1-19/32	910115937	Punch	1.5937	Buy Online at: Americanwhitney.com
		910215997	Die	1.5997	
1-5/8	9101+9102M1-5/8	910116250	Punch	1.6250	
		910216310	Die	1.6310	
1-21/32	9101+9102M1-21/32	910116562	Punch	1.6562	Buy Online at: Americanwhitney.com
		910216622	Die	1.6622	
1-11/16	9101+9102M1-11/16	910116875	Punch	1.6875	
		910216935	Die	1.6935	
1-23/32	9101+9102M1-23/32	910117187	Punch	1.7187	Buy Online at: Americanwhitney.com
		910217247	Die	1.7247	
1-3/4	9101+9102M1-3/4	910117500	Punch	1.7500	
		910217560	Die	1.7560	
1-25/32	9101+9102M1-25/32	910117812	Punch	1.7812	Buy Online at: Americanwhitney.com
		910217872	Die	1.7872	
1-13/16	9101+9102M1-13/16	910118125	Punch	1.8125	
		910218185	Die	1.8185	
1-27/32	9101+9102M1-27/32	910118437	Punch	1.8437	Buy Online at: Americanwhitney.com
		910218497	Die	1.8497	
1-7/8	9101+9102M1-7/8	910118750	Punch	1.8750	
		910218810	Die	1.8810	
1-29/32	9101+9102M1-29/32	910119062	Punch	1.9062	Buy Online at: Americanwhitney.com
		910219122	Die	1.9122	
1-15/16	9101+9102M1-15/16	910119375	Punch	1.9375	
		910219435	Die	1.9435	
1-31/32	9101+9102M1-31/32	910119687	Punch	1.9687	Buy Online at: Americanwhitney.com
		910219747	Die	1.9747	
2"	9101+9102M2	910120000	Punch	2.0000	
		910220060	Die	2.0060	

We also make Punches & Dies in Non-Standard forms such as:
Rounds • Rectangles • “D” Shapes • “DD” Shapes • Hex • Obround
 Call today with specifics for a Quote!

No.91 & 92 Series Bench Presses

Punches and Dies for material thickness 12ga. – 5/32"

Diameter	Set Of Punch & Die Part No.	Individual Part Number	Punch Or Die	Round Decimal Eq.	Your can order Online or order on the phone!
1/16	9101+9102S1/16	910100625	Punch	0.0625	Buy Online at: Americanwhitney.com
		910200841	Die	0.0841	
3/32	9101+9102S3/32	910100937	Punch	0.0937	
		910201153	Die	0.1153	
1/8	9101+9102S1/8	910101250	Punch	0.1250	Buy Online at: Americanwhitney.com
		910201466	Die	0.1466	
5/32	9101+9102S5/32	910101562	Punch	0.1562	
		910201778	Die	0.1778	
3/16	9101+9102S3/16	910101875	Punch	0.1875	Buy Online at: Americanwhitney.com
		910202091	Die	0.2091	
7/32	9101+9102S7/32	910102187	Punch	0.2187	
		910202403	Die	0.2403	
1/4	9101+9102S1/4	910102500	Punch	0.2500	Buy Online at: Americanwhitney.com
		910202716	Die	0.2716	
9/32	9101+9102S9/32	910102812	Punch	0.2812	
		910203028	Die	0.3028	
5/16	9101+9102S5/16	910103125	Punch	0.3125	Buy Online at: Americanwhitney.com
		910203341	Die	0.3341	
11/32	9101+9102S11/32	910103437	Punch	0.3437	
		910203653	Die	0.3653	
3/8	9101+9102S3/8	910103750	Punch	0.3750	Buy Online at: Americanwhitney.com
		910203966	Die	0.3966	
13/32	9101+9102S13/32	910104062	Punch	0.4062	
		910204278	Die	0.4278	
7/16	9101+9102S7/16	910104375	Punch	0.4375	Buy Online at: Americanwhitney.com
		910204591	Die	0.4591	
15/32	9101+9102S15/32	910104687	Punch	0.4687	
		910204903	Die	0.4903	
1/2	9101+9102S1/2	910105000	Punch	0.5000	Buy Online at: Americanwhitney.com
		910205216	Die	0.5216	
17/32	9101+9102S17/32	910105312	Punch	0.5312	
		910205528	Die	0.5528	

We also make Punches & Dies in Non-Standard forms such as:
Rounds • Rectangles • “D” Shapes • “DD” Shapes • Hex • Obround
 Call today with specifics for a Quote!

No.91 & 92 Series Bench Presses

Punches and Dies for material thickness 12ga. – 5/32" (cont.)

Diameter	Set Of Punch & Die Part No.	Individual Part Number	Punch Or Die	Round Decimal Eq.	Your can order Online or order on the phone!
9/16	9101+9102S9/16	910105625	Punch	0.5625	Buy Online at: Americanwhitney.com
		910205841	Die	0.5841	
19/32	9101+9102S19/32	910105937	Punch	0.5937	
		910206153	Die	0.6153	
5/8	9101+9102S5/8	910106250	Punch	0.6250	Buy Online at: Americanwhitney.com
		910206466	Die	0.6466	
21/32	9101+9102S21/32	910106562	Punch	0.6562	
		910206778	Die	0.6778	
11/16	9101+9102S11/16	910106875	Punch	0.6875	Buy Online at: Americanwhitney.com
		910207091	Die	0.7091	
23/32	9101+9102S23/32	910107187	Punch	0.7187	
		910207403	Die	0.7403	
3/4	9101+9102S3/4	910107500	Punch	0.7500	Buy Online at: Americanwhitney.com
		910207716	Die	0.7716	
25/32	9101+9102S25/32	910107812	Punch	0.7812	
		910208028	Die	0.8028	
13/16	9101+9102S13/16	910108125	Punch	0.8125	Buy Online at: Americanwhitney.com
		910208341	Die	0.8341	
27/32	9101+9102S27/32	910108437	Punch	0.8437	
		910208653	Die	0.8653	
7/8	9101+9102S7/8	910108750	Punch	0.8750	Buy Online at: Americanwhitney.com
		910208966	Die	0.8966	
29/32	9101+9102S29/32	910109062	Punch	0.9062	
		910209278	Die	0.9278	
15/16	9101+9102S15/16	910109375	Punch	0.9375	Buy Online at: Americanwhitney.com
		910209591	Die	0.9591	
31/32	9101+9102S31/32	910109687	Punch	0.9687	
		910209903	Die	0.9903	
1"	9101+9102S1	910110000	Punch	1.0000	Buy Online at: Americanwhitney.com
		910210216	Die	1.0216	
1-1/32	9101+9102S1-1/32	910110312	Punch	1.0312	
		910210528	Die	1.0528	

We also make Punches & Dies in Non-Standard forms such as:
Rounds • Rectangles • "D" Shapes • "DD" Shapes • Hex • Obround
 Call today with specifics for a Quote!

No.91 & 92 Series Bench Presses

Punches and Dies for material thickness 12ga. – 5/32" (cont.)

Diameter	Set Of Punch & Die Part No.	Individual Part Number	Punch Or Die	Round Decimal Eq.	Your can order Online or order on the phone!
1-1/16	9101+9102S1-1/16	910110625	Punch	1.0625	Buy Online at: Americanwhitney.com
		910210841	Die	1.0841	
1-3/32	9101+9102S1-3/32	910110937	Punch	1.0937	
		910211153	Die	1.1153	
1-1/8	9101+9102S1-1/8	910111250	Punch	1.1250	Buy Online at: Americanwhitney.com
		910211466	Die	1.1466	
1-5/32	9101+9102S1-5/32	910111562	Punch	1.1562	
		910211778	Die	1.1778	
1-3/16	9101+9102S1-3/16	910111875	Punch	1.1875	Buy Online at: Americanwhitney.com
		910212091	Die	1.2091	
1-7/32	9101+9102S1-7/32	910112187	Punch	1.2187	
		910212403	Die	1.2403	
1-1/4	9101+9102S1-1/4	910112500	Punch	1.2500	Buy Online at: Americanwhitney.com
		910212716	Die	1.2716	
1-9/32	9101+9102S1-9/32	910112812	Punch	1.2812	
		910213028	Die	1.3028	
1-5/16	9101+9102S1-5/16	910113125	Punch	1.3125	Buy Online at: Americanwhitney.com
		910213341	Die	1.3341	
1-11/32	9101+9102S1-11/32	910113437	Punch	1.3437	
		910213653	Die	1.3653	
1-3/8	9101+9102S1-3/8	910113750	Punch	1.3750	Buy Online at: Americanwhitney.com
		910213966	Die	1.3966	
1-13/32	9101+9102S1-13/32	910114062	Punch	1.4062	
		910214278	Die	1.4278	
1-7/16	9101+9102S1-7/16	910114375	Punch	1.4375	Buy Online at: Americanwhitney.com
		910214591	Die	1.4591	
1-15/32	9101+9102S1-15/32	910114687	Punch	1.4687	
		910214903	Die	1.4903	
1-1/2	9101+9102S1-1/2	910115000	Punch	1.5000	Buy Online at: Americanwhitney.com
		910215216	Die	1.5216	
1-17/32	9101+9102S1-17/32	910115312	Punch	1.5312	
		910215528	Die	1.5528	

We also make Punches & Dies in Non-Standard forms such as:
Rounds • Rectangles • “D” Shapes • “DD” Shapes • Hex • Obround
 Call today with specifics for a Quote!

No.91 & 92 Series Bench Presses

Punches and Dies for material thickness 12ga. – 5/32" (cont.)

Diameter	Set Of Punch & Die Part No.	Individual Part Number	Punch Or Die	Round Decimal Eq.	Your can order Online or order on the phone!
1-9/16	9101+9102S1-9/16	910115625	Punch	1.5625	Buy Online at: Americanwhitney.com
		910215841	Die	1.5841	
1-19/32	9101+9102S1-19/32	910115937	Punch	1.5937	
		910216153	Die	1.6153	
1-5/8	9101+9102S1-5/8	910116250	Punch	1.6250	Buy Online at: Americanwhitney.com
		910216466	Die	1.6466	
1-21/32	9101+9102S1-21/32	910116562	Punch	1.6562	
		910216778	Die	1.6778	
1-11/16	9101+9102S1-11/16	910116875	Punch	1.6875	Buy Online at: Americanwhitney.com
		910217091	Die	1.7091	
1-23/32	9101+9102S1-23/32	910117187	Punch	1.7187	
		910217403	Die	1.7403	
1-3/4	9101+9102S1-3/4	910117500	Punch	1.7500	Buy Online at: Americanwhitney.com
		910217716	Die	1.7716	
1-25/32	9101+9102S125/32	910117812	Punch	1.7812	
		910218028	Die	1.8028	
1-13/16	9101+9102S1-13/16	910118125	Punch	1.8125	Buy Online at: Americanwhitney.com
		910218341	Die	1.8341	
1-27/32	9101+9102S1-27/32	910118437	Punch	1.8437	
		910218653	Die	1.8653	
1-7/8	9101+9102S1-7/8	910118750	Punch	1.8750	Buy Online at: Americanwhitney.com
		910218966	Die	1.8966	
1-29/32	9101+9102S1-29/32	910119062	Punch	1.9062	
		910219278	Die	1.9278	
1-15/16	9101+9102S1-15/16	910119375	Punch	1.9375	Buy Online at: Americanwhitney.com
		910219591	Die	1.9591	
1-31/32	9101+9102S1-31/32	910119687	Punch	1.9687	
		910219903	Die	1.9903	
2"	9101+9102S2	910120000	Punch	2.0000	Buy Online at: Americanwhitney.com
		910220216	Die	2.0216	

We also make Punches & Dies in Non-Standard forms such as:
Rounds • Rectangles • "D" Shapes • "DD" Shapes • Hex • Obround
 Call today with specifics for a Quote!

Whitney Hand Tools
Since 1907



815-965-1792

www.AmericanWhitney.com